

sample slope --- 3.44%

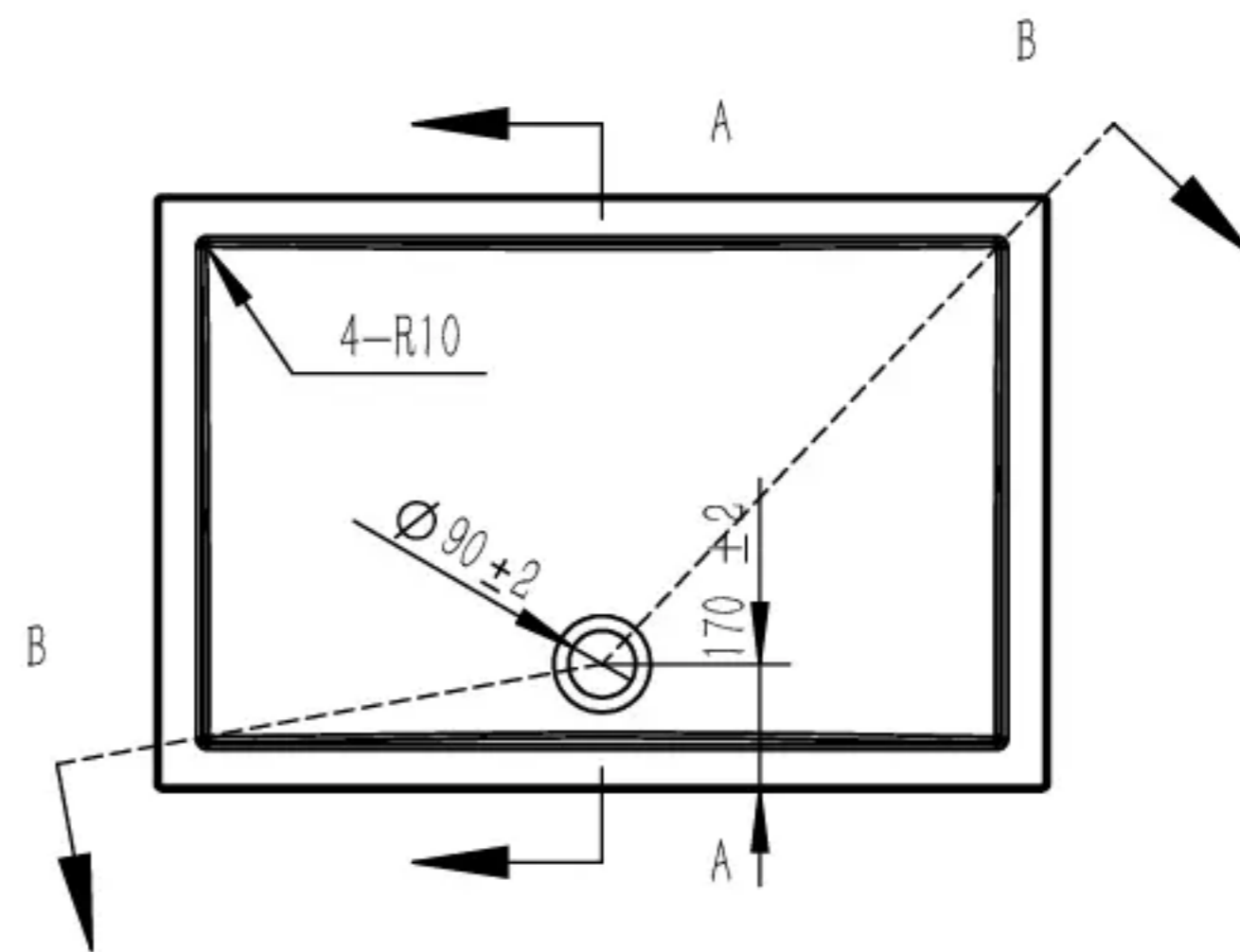

sample slope --- 2.82%

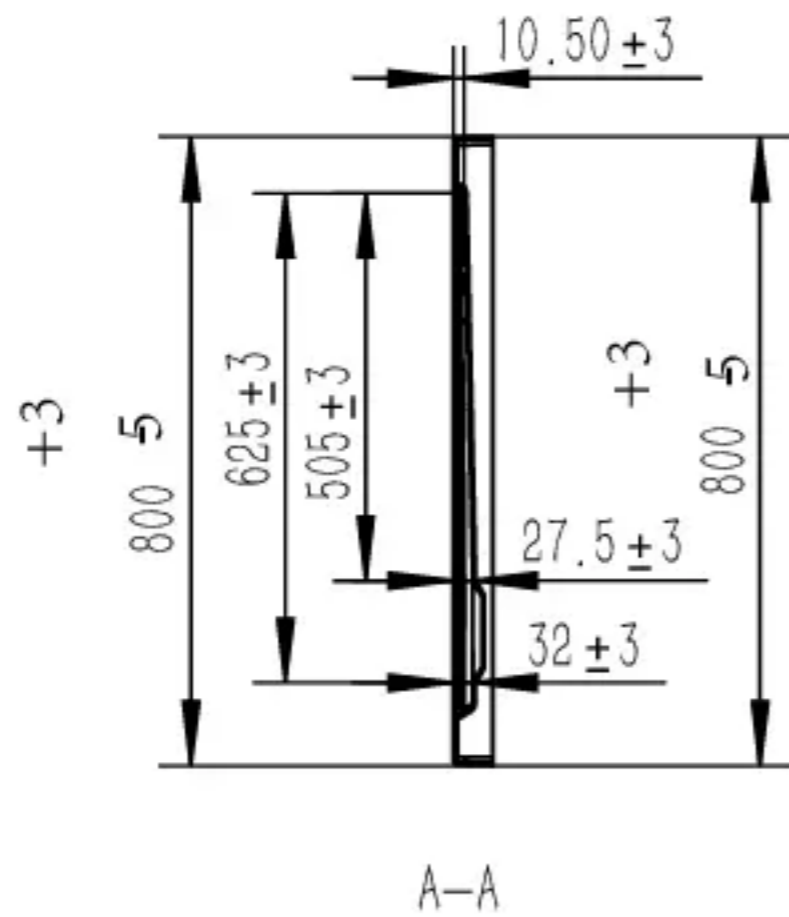
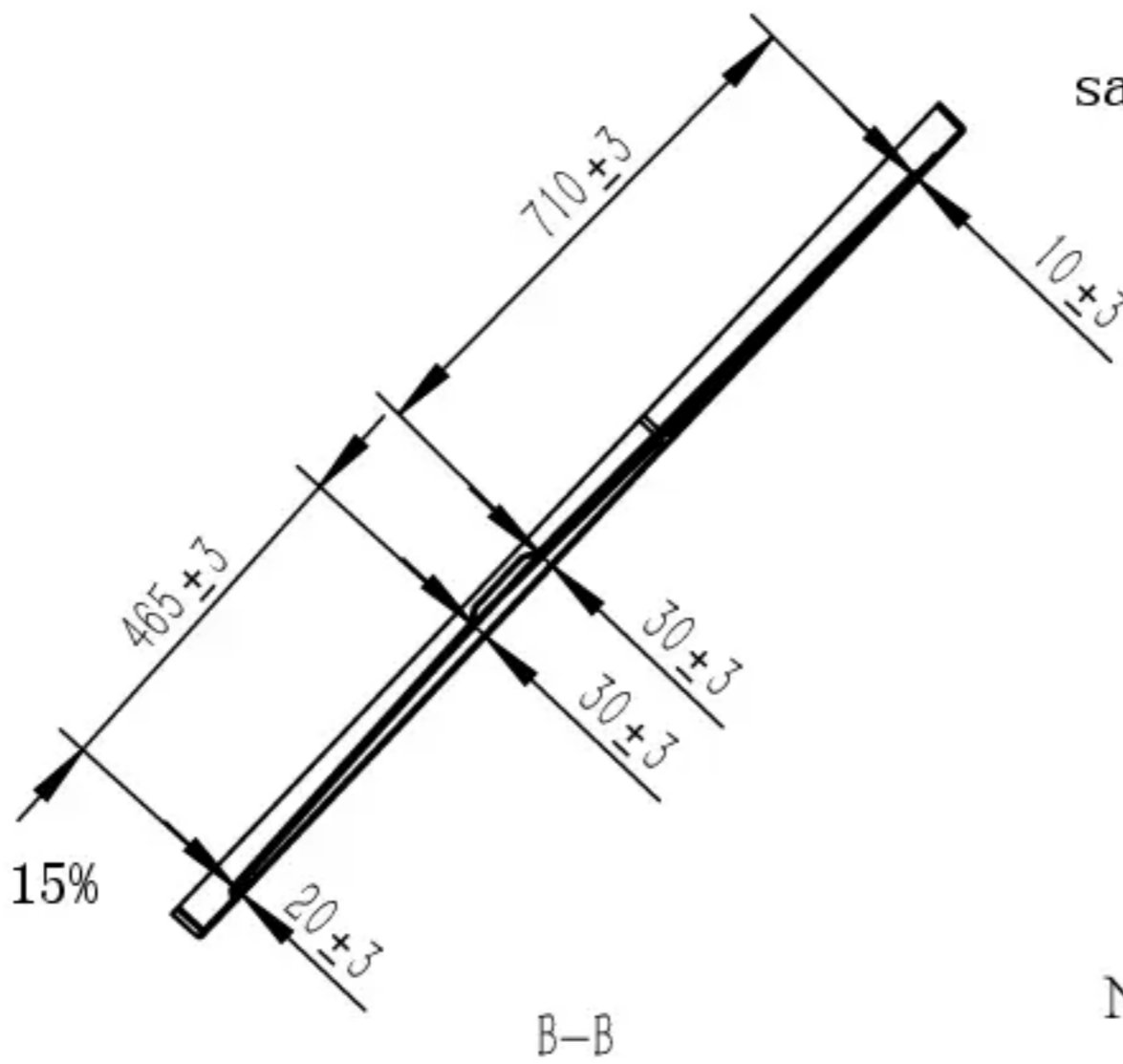

sample slope --- 2.15%

N.W./G.W.:14.6KGS/16.4KGS

weight tolerance :-5%,+10%

ROYOLED					
		design		date	
		drawing	Mr.Pei	date	2018/9/25
Name	Rectangular tray (800X1200)*50		Checking	date	
			Auditing	date	
ERP NO.			Allowing	date	
Unit	mm	Rate	1.20		
Material					
			A4		Editio 01.0 Page 1/1