

# Product technical data sheet

ADEO Ref

845103

EAN Code

3276000547037

## Explosion Drawing

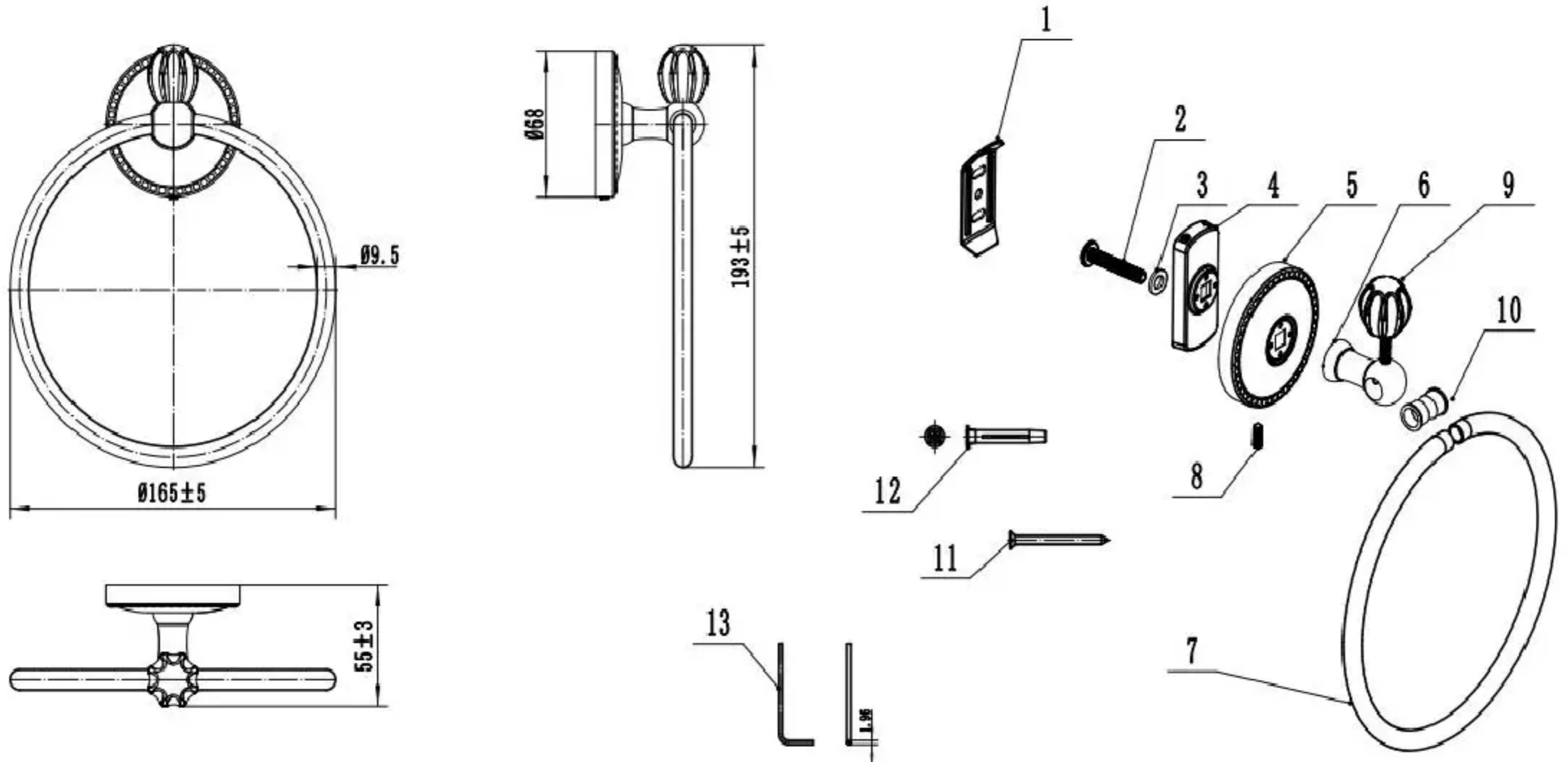

单位: mm

Parts No.	Quantity	Spec	Material & Surface process
1	1	T=1.0mm	Steel with zinc plating
2	1	M6*30	Steel with zinc plating
3	1	C6	Steel with zinc plating
4	1	T=1.0mm	Steel with zinc plating
5	1	T=0.6mm	Steel with chrome finished
6	1		Zinc alloy with chrome finished
7	1	$\varnothing 9.5 \times 0.8$	Steel with chrome finished
8	1	M4*12	SS201
9	1		Ceramic and steel
10	2		PE
11	2	4.0*50	SS201
12	2	$\varnothing 6.0 \times 40$	Plastic
13	1	#2.0	Wrench