

EAN CODE : 3276000589839
 EAN CODE : 3276000589815
 EAN CODE : 3276000596783
 EAN CODE : 3276000632511

FR Manuel d'Instructions

ES Manual de Instrucciones

PT Manual de Instruções

IT Manuale di Istruzioni

EL Εγχειρίδιο Οδηγιών

PL Instrukcja Obsługi

RU Руководства по
Эксплуатации

KZ Пайдаланушы Нұсқаулығы

UA Інструкція з Експлуатації

RO Manual de Instrucțiuni

BR Manual de Instruções

EN Instructions Manual

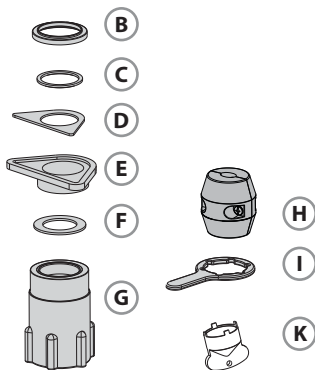
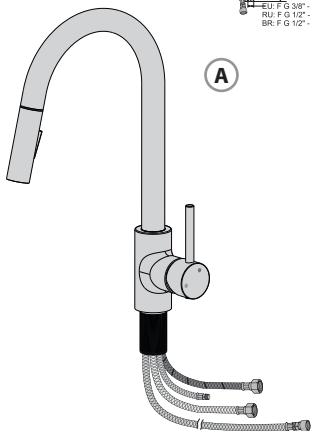
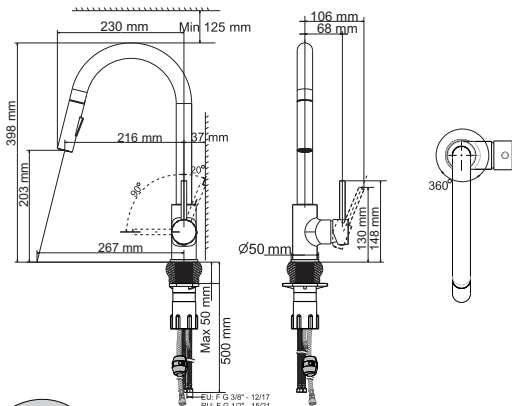



FR: Préparation / ES: Preparación / PT: Preparação / IT: Preparazione / EL: Προετοιμασία /
PL: Przygotowanie / RU: Подготовка / KZ: Дайындау / UA: Підготування / RO: Pregătire / BR: Preparação /
EN: Preparation



FR: Montage / ES: Montaje / PT: Montagem / IT: Montaggio / EL: Συναρμολόγηση /
PL: Montaż / RU: Сборка / KZ: Монтаждау / UA: Збірка / RO: Montaj / BR: Montagem /
EN: Assembly



FR: Utilisation eau chaude-eau froide/ ES: Utilización agua caliente-agua fría/ PT: Utilização água quente-água fria/
IT: Uso acqua calda-acqua fredda/ EL: Χρήση ζεστού-κρύου νερού/ PL: Użytkowanie zimnej wody-gorącej wody/
RU: использование горячей и холодной воды/ KZ: Суық және ыстық суды қолдану/
UA: використання гарячої - холодної води/ RO: Utilizare apă caldă-apă rece/
BR: Uso de água quente e fria/ EN: Using hot and cold water

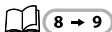

FR: Changement de cartouche/ ES: Cambio de cartucho/ IT: Cambio cartuccia/ PT: Mudança de cartucho/
EL: Αλλαγή φυσιγγίου/ PL: Wymiana wkładu / RU: Смена картриджа/ KZ: Картриджді ауыстыру/
UA: заміна картриджа/ RO: Schimbare cartus/ BR: Substituição de cartucho/ EN: Replacing the cartridge



FR: Changement de mousser/ ES: Cambio de aireador/ PT: Mudança de arejador/ IT: Cambio rompigetto/
EL: Αλλαγή αεράτορα / PL: Wymiana perlatora / RU: Смена аэратора/ KZ: Ауақанықтырғышты ауыстыру/
UA: заміна аератора/ RO: Schimbare aerator/ BR: Substituição do aerador/ EN: Replacing the aerator



FR: Changement de flexibles/ ES: Cambio de flexibles / PT: Mudança de flexíveis/ IT: Cambio flessibili/
EL: Αλλαγή λάστιχων/ PL: Wymiana wężyków instalacyjnych / RU: Смена гибкого шланга для смесителя/
UA: заміна гнучкого шланга для змішувача/ KZ: Қоспалауышқа арналған иілгіш шлангты ауыстыру/
RO: Schimbare furtune flexibile/ BR: Substituição das mangueiras/ EN: Replacing the hoses





FR: Préparation / ES: Preparación / PT: Preparação / IT: Preparazione / EL: Προετοιμασία /
PL: Przygotowanie / RU: Подготовка / KZ: Дайындау / UA: Підготування / RO: Pregătire /
BR: Preparação / EN: Preparation

1

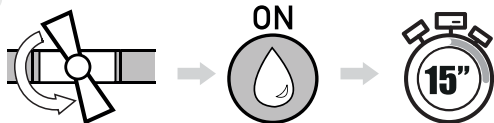

2

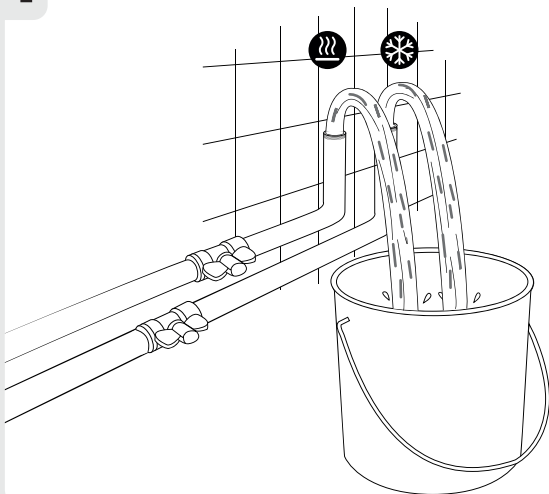

3

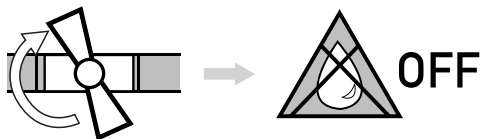

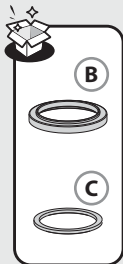

FR: Montage / ES: Montaje / PT: Montagem / IT: Montaggio / EL: Συναρμολόγηση /
PL: Montaż / RU: Сборка / KZ: Монтаждау / UA: Збірка / RO: Montaj / BR: Montagem /
EN: Assembly

1

1

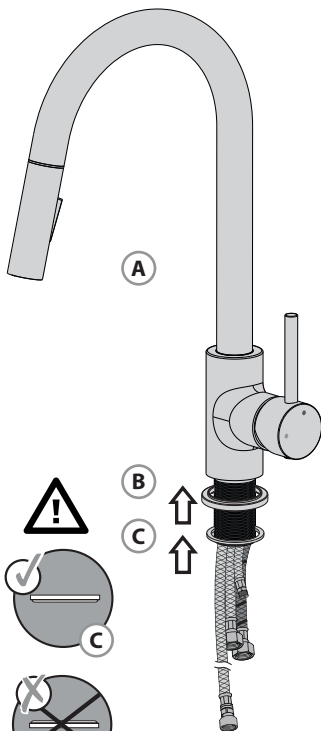

2

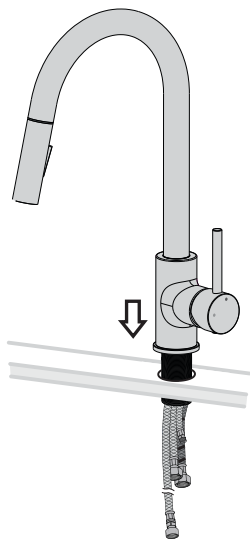

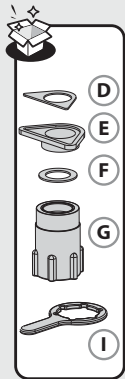

3

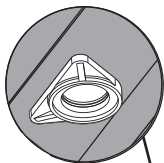
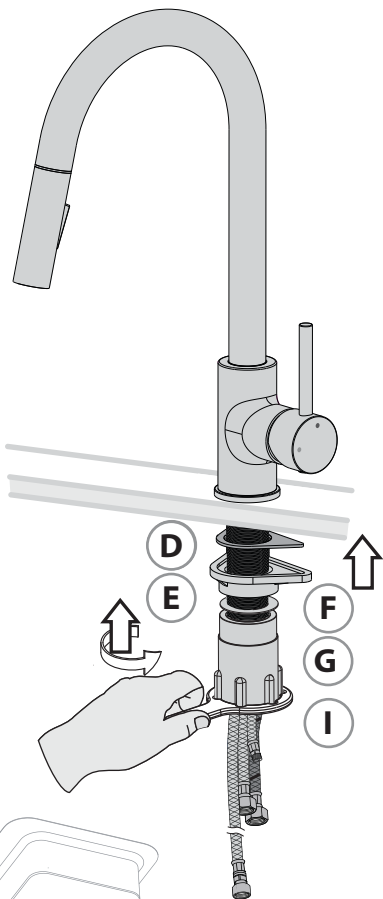



4

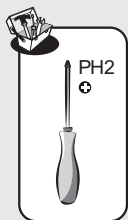
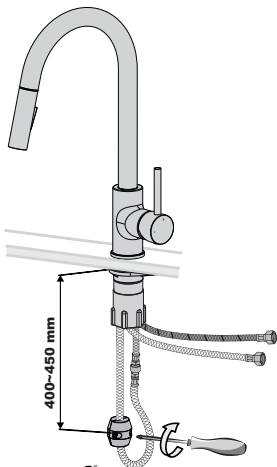
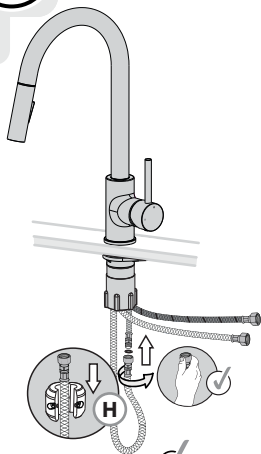

PH2
+

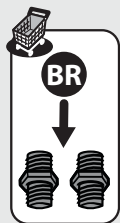

5

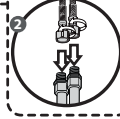
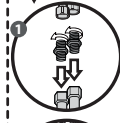
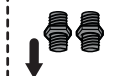
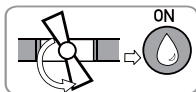
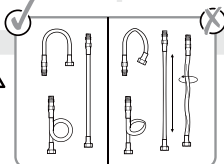
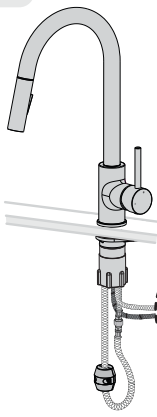



FR: Utilisation eau chaude-eau froide/ ES: Utilización agua caliente-agua fría/ PT: Utilização água quente-água fria/
IT: Uso acqua calda-acqua fredda/ EL: Χρήση ζεστού-κρύου νερού/ PL: Użytkowanie zimnej wody-gorącej wody/
RU: использование горячей и холодной воды/ KZ: Суық және ыстық суды қолдану/
UA: використання гарячої - холодної води/ RO: Utilizare apă caldă-apă rece/
BR: Uso de água quente e fria/ EN: Using hot and cold water

1

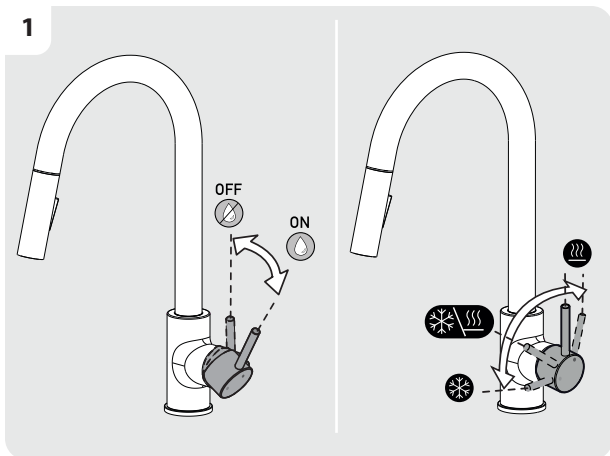

2

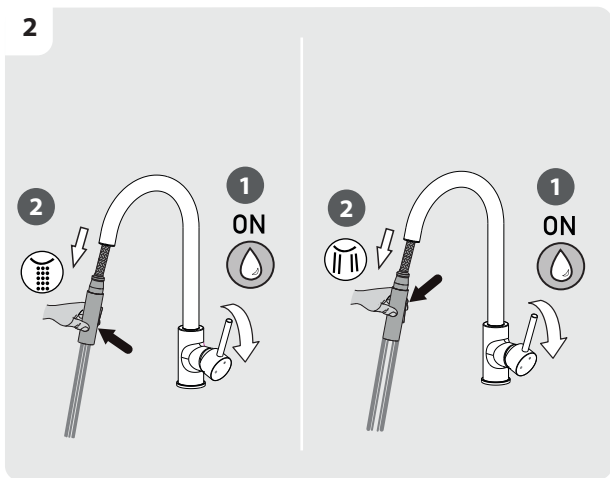



3

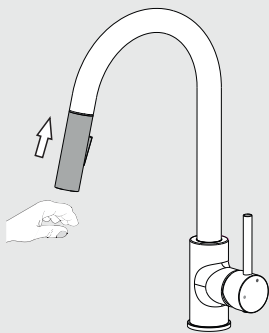
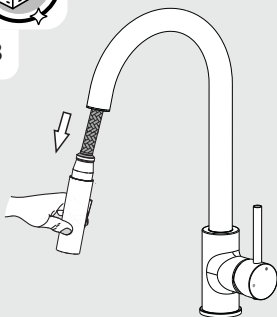

4

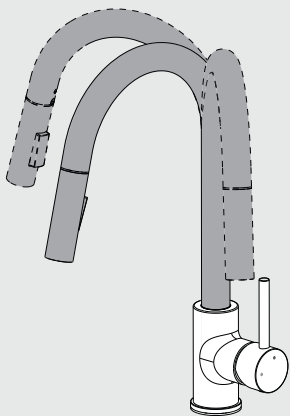

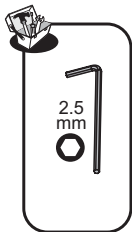

FR: Changement de cartouche/ ES: Cambio de cartucho/ IT: Cambio cartuccia/ PT: Mudança de cartucho/
 EL: Αλλαγή φουσιγγίου/ PL: Wymiana wkładu / RU: Смена картриджа/ KZ: Картриджді ауыстыру/
 UA: Заміна картриджа/ RO: Schimbare cartuş/ BR: Substituição de cartucho/ EN: Replacing the cartridge

1

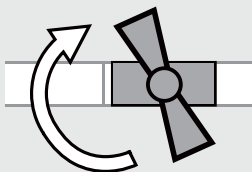

2

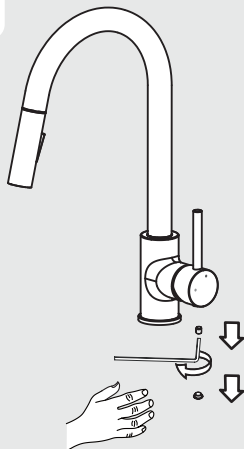

3

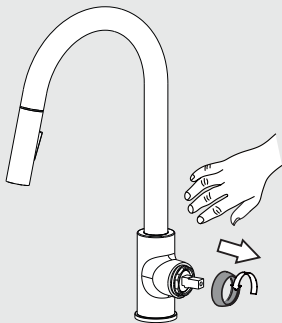

4

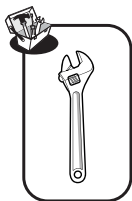
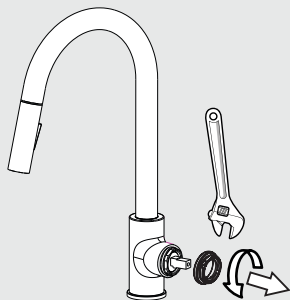



FR: Changement de cartouche/ ES: Cambio de cartucho/ IT: Cambio cartuccia/ PT: Mudança de cartucho/
EL: Αλλαγή φουσιγγίου/ PL: Wymiana wkładu / RU: Смена картриджа/ KZ: Картриджді ауыстыру/
UA: Заміна картриджа/ RO: Schimbare cartuş/ BR: Substituição de cartucho/ EN: Replacing the cartridge

5

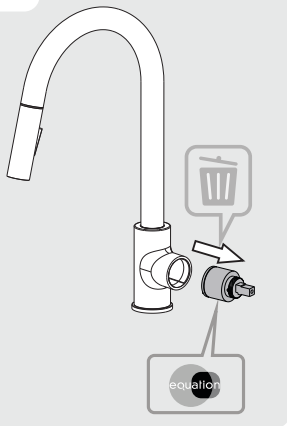

6

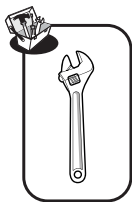
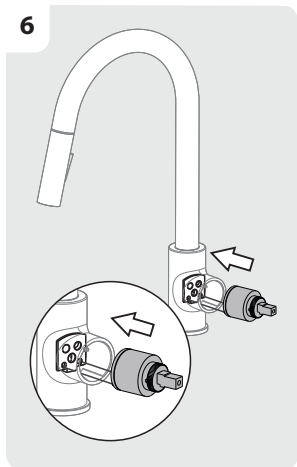

7

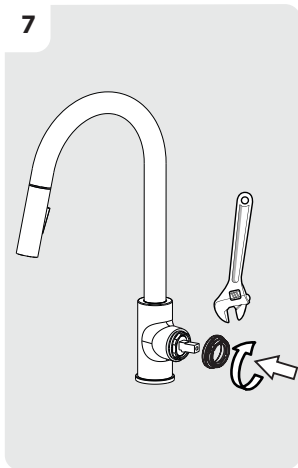

8

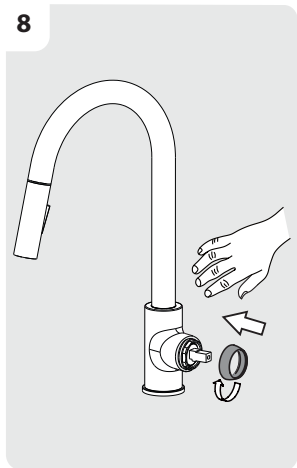

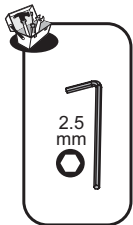

FR: Changement de cartouche/ ES: Cambio de cartucho/ IT: Cambio cartuccia/ PT: Mudança de cartucho/
EL: Αλλαγή φουγγιγίου/ PL: Wymiana wkładu / RU: Смена картриджа/ KZ: Картриджді ауыстыру/
UA: Заміна картриджа/ RO: Schimbare cartuş/ BR: Substituição de cartucho/ EN: Replacing the cartridge

9

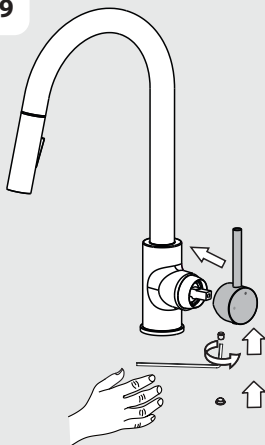

10

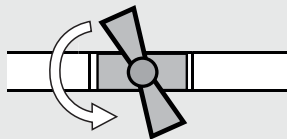



FR: Changement de mousseur/ ES: Cambio de aireador/ PT: Mudança de arejador/ IT: Cambio rompigetto/
 EL: Αλλαγή αεράτορα / PL: Wymiana perlatora / RU: Смена аэратора/ KZ: Ауақанықтырғышты ауыстыру/
 UA: Заміна аератора/ RO: Schimbare aerator/ BR: Substituição do aerador/ EN: Replacing the aerator

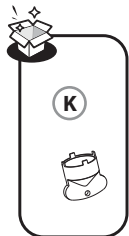

1

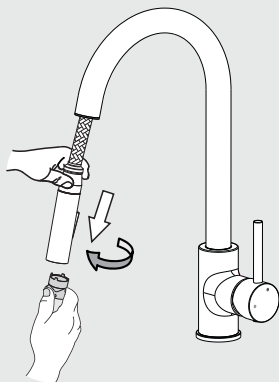

2

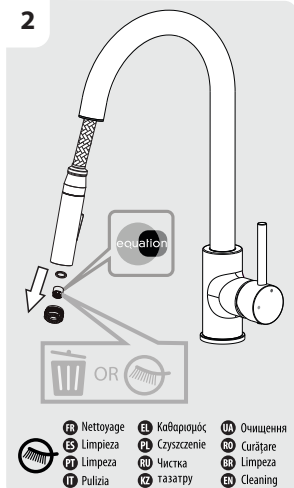

3

FR Vinaigre	IT Aceto	RU Уксус	RO Oțet
ES Vinagre	EL Ξίδι	KZ Сірке су	BR Vinagre
PT Vinagre	PL Ocet	UA Оцет	EN Vinegar

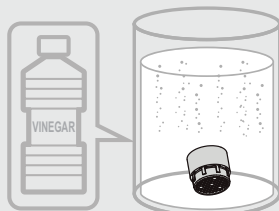

4

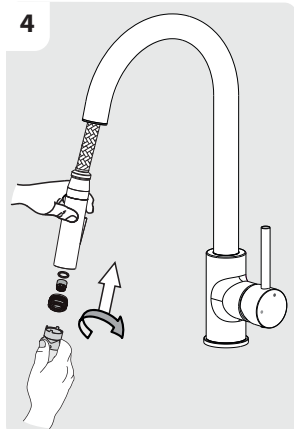



FR: Changement de flexibles / ES: Cambio de flexibles / PT: Mudança de flexíveis/ IT: Cambio flessibili/
EL: Αλλαγή λάστιχων/ PL: Wymiana wężyków instalacyjnych / RU: Смена гибкого шланга для смесителя/
UA: Заміна гнучкого шланга для змішувача/ KZ: Қоспалауышқа арналған иілгіш шлангты ауыстыру/
RO: Schimbare furtune flexibile/ BR: Substituição das mangueiras/ EN: Replacing the hoses

1

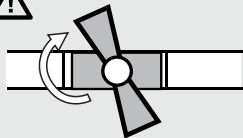

OFF

2

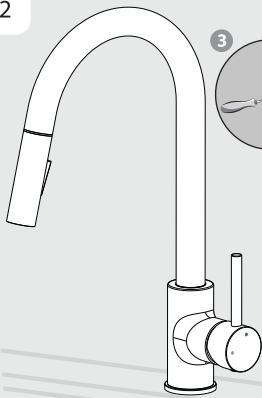
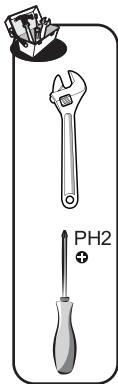

3

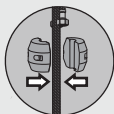

1



2



3

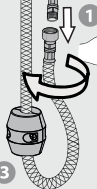



FR: Changement de flexibles / ES: Cambio de flexibles / PT: Mudança de flexíveis / IT: Cambio flessibili /
EL: Αλλαγή λάστιχων / PL: Wymiana wężyków instalacyjnych / RU: Смена гибкого шланга для смесителя /
UA: Заміна гнучкого шланга для змішувача / KZ: Қоспалауышқа арналған иілгіш шлангты ауыстыру /
RO: Schimbare furtune flexibile / BR: Substituição das mangueiras / EN: Replacing the hoses

3

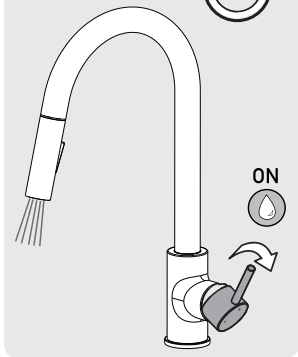

4

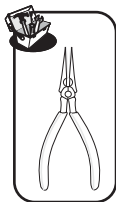
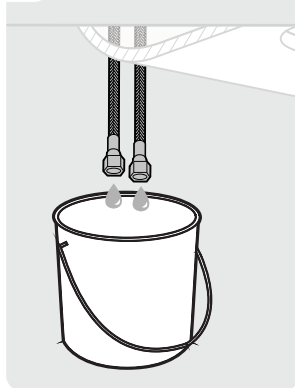

5

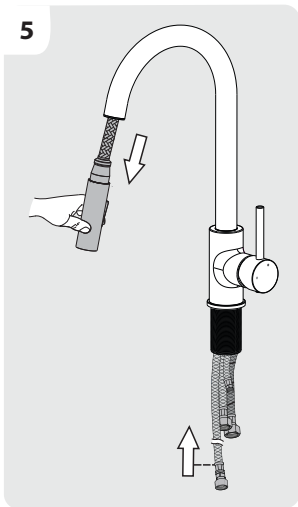

6

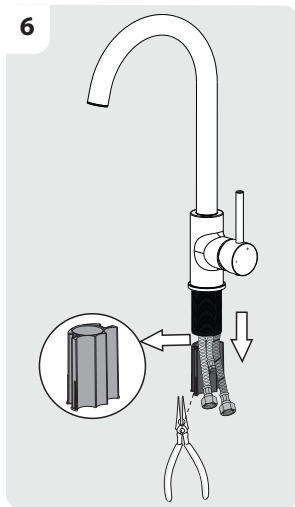



FR: Changement de flexibles / ES: Cambio de flexibles / PT: Mudança de flexíveis / IT: Cambio flessibili /
EL: Αλλαγή λάστιχων / PL: Wymiana wężyków instalacyjnych / RU: Смена гибкого шланга для смесителя /
UA: Заміна гнучкого шланга для змішувача / KZ: Қоспалауышқа арналған иілгіш шлангты ауыстыру /
RO: Schimbare furtune flexibile / BR: Substituição das mangueiras / EN: Replacing the hoses

7

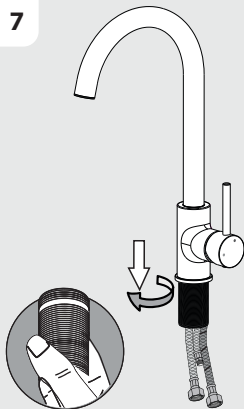

8

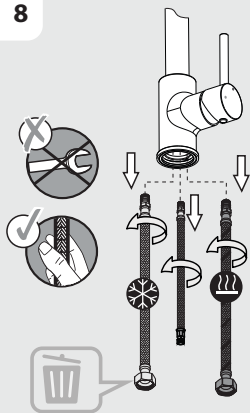

9

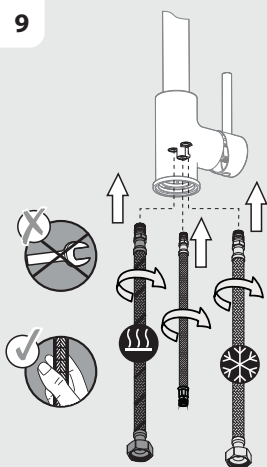

10

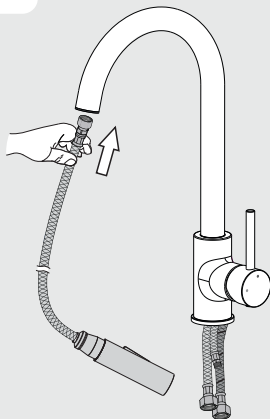



FR: Changement de flexibles / ES: Cambio de flexibles / PT: Mudança de flexíveis / IT: Cambio flessibili /
EL: Αλλαγή λάστιχων / PL: Wymiana wężyków instalacyjnych / RU: Смена гибкого шланга для смесителя /
UA: Заміна гнучкого шланга для змішувача / KZ: Қоспалауышқа арналған илгіш шлангты ауыстыру /
RO: Schimbare furtune flexibile / BR: Substituição das mangueiras / EN: Replacing the hoses

11

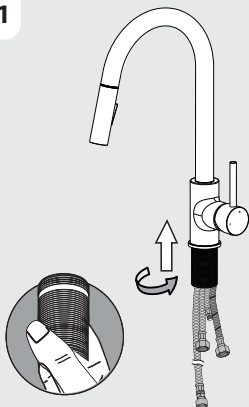

12

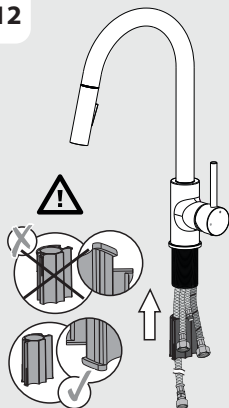

13

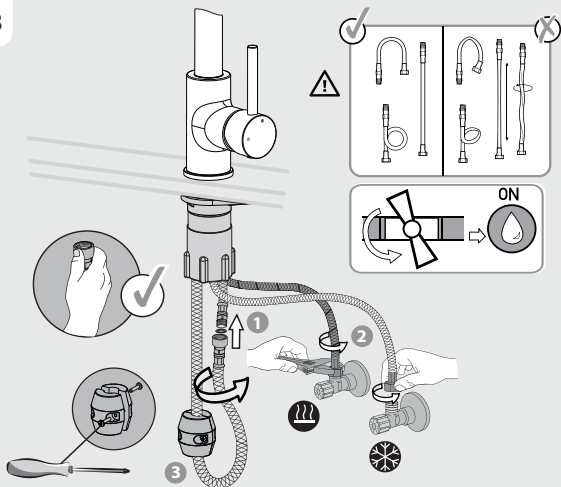



Eau claire / Agua limpia / Água limpa / Acqua pulita / Καθαρό νερό / Czysta woda / Чистая вода / таза су / Чиста вода /
Apă curată / Água limpa / Clean water



Sans solvant / Sin disolvente / Sem solventes / Senza solventi / Χωρίς διαλυτικά / Bez rozpuszczalnika / Без растворителя /
еріткішсіз / Без розчинника / Fără solvent / Sem solventes / Solvent-free

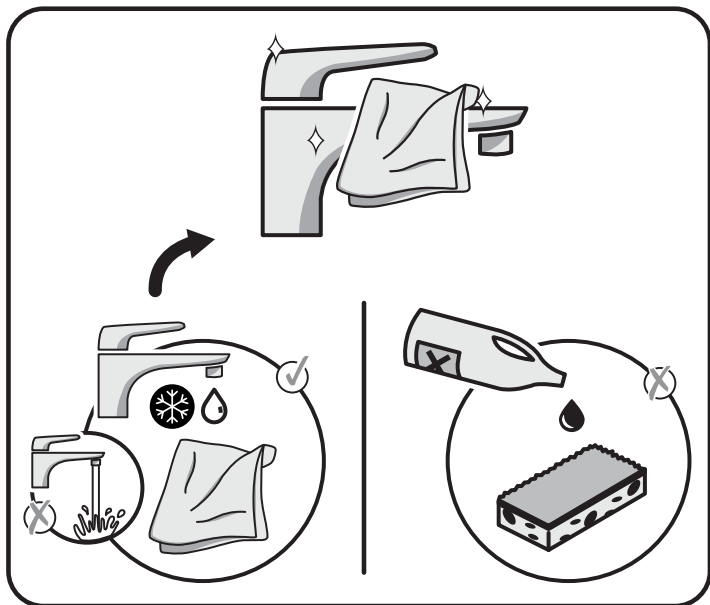

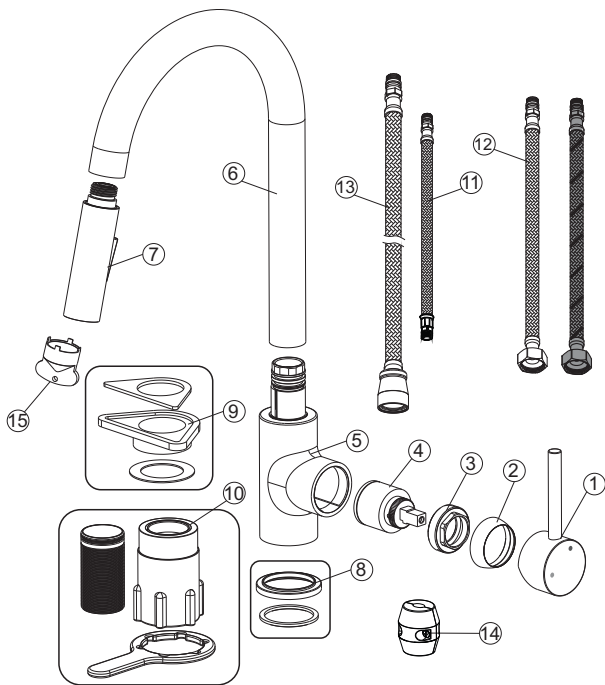

No	Description	Code No.	Q'Ty	Remark
1	Handle	5710Y027A0XCP/BN	1	
2	Beautify Cover	5614B205A0ACP/BN	1	
3	Pressing Nut	5613B187A1ANT	1	
4	Cartridge	SN-35 COLD S/D MIRROR 08SN35S1501	1	
5	Body	5690Y629KAXCP/BN	1	
6	Spout	5628G209A0FCP/BN	1	
7	Pull -out spout(aeartor)	5629Z441A0TCP/BN (44.2100.000)	1	
8	Base	5633Y172A0XCP/BN	1	
9	Triangle base	5635Q319A0PNT	1	
10	Fixing set	5626Q086A0TNT	1	
11	Spout supply hose	TAQ PEX DN6 ACB M8x1 L12 M11x1-300-QB	1	
12	Supply hose	TAQ-PEX-DN6-ACB H3/8-M8x1 L12-550	2	
13	Pull-out spout hose	TWIST-M11x1-H1/2con-1500	1	
14	Counter weight	5635Q328A1TNT	1	
15	Aerator wrench	5635Q842A0TNT	1	

- FR:** La présence sur ce robinet d'un ou plusieurs clapet(s) anti-retour est nécessaire au bon fonctionnement de l'ensemble de votre installation en eau. Ne tentez pas de le(s) retirer.
- ES:** La presencia en este grifo de una o de varias válvula(s) de retención es necesaria para el buen funcionamiento del conjunto de su instalación de agua. No intente retirarla(s).
- PT:** A presença nesta torneira de uma ou mais válvula(s) de retenção é necessária para o funcionamento adequado de toda a instalação de água. Não tente removê-la(s).
- IT:** La presenza su questo rubinetto di una o più valvole anti riflusso è necessaria per il buon funzionamento della totalità del vostro impianto in acqua. Non tentare di rimuoverle.
- PL:** Obecność jednego lub więcej zaworów zwrotnych kranu jest niezbędna dla prawidłowego funkcjonowania całej instalacji wodnej. Nie należy ich usuwać.
- EL:** Η παρουσία σε αυτήν την μπαταρία, μίας ή περισσοτέρων, βαλβίδων αντεπιστροφής είναι απαραίτητη για την καλή λειτουργία του συνόλου της υδραυλικής σας εγκατάστασης. Μην επιχειρήσετε να τις αποσπάσετε.
- RU:** Наличие на этом кране одного или нескольких обратных клапанов необходимо для для правильной работы всей водопроводной установки. Не пытайтесь его/их снимать.
- KZ:** Бұл шүмектегі бір немесе бірнеше қайырмалы қақпақашының болуы түгел су құбыры қондырғысының дұрыс жұмыс жасауы үшін қажет. Оны/оларды алып тастауға тырыспаңыз.
- UA:** Наявність на цьому крані одного або декількох зворотних клапанів необхідна для правильної роботи всієї водопровідної установки. Не намагайтеся його/їх знімати.
- RO:** Prezența pe această robinet a unei sau mai multor supape de reținere este necesară pentru buna funcționare a întregii dvs. instalații de apă. Nu încercați să le eliminați.
- BR:** A presença de uma ou mais válvula(s) anti-retorno nessa torneira é necessária para o funcionamento adequado da sua instalação de água. Não tente remover a(s) válvula(s).
- EN:** The presence of one or more anti-return valve(s) on this tap is required for proper operation of your water setup. Please do not attempt to remove it/them.



Certificado de conformidad sanitaria.
 Atestado de conformidade sanitária.
 certificado di conformità sanitaria.
 Βεβαίωση υγειονομικής συμμόρφωσης.
 Certyfikat zgodności sanitarnej.
 Декларация о соответствии санитарным нормам
 Санитарлық талаптарға сәйкестік декларациясы
 Декларация про відповідність санітарним нормам
 Atestat de conformitate sanitară
 Certificado de conformidade sanitária.
 Declaration of sanitary conformity.
 Attestation de conformité sanitaire



Garantie 10 ans / 10 años de garantía / Garantia de 10 anos / Garanzia 10 Anni /
 Εγγύηση 10 ετών / Gwarancja 10-letnia / Гарантия 10 года / Кепілдік 10 жыл /
 Гарантія 10 років / Garantie 10 ani / 10 años de garantía / 10-year guarantee

Made in Vietnam 2018

ADEO Services - 135 Rue Sadi Carnot - CS 00001
 59790 RONCHIN - France

UA ТОВ «Леруа Мерлен Україна»,
 вул. Полярна 17а, м. Київ 04201, Україна

RU ООО ЛЕРУА МЕРЛЕН ВОСТОК, 141031, Московская
 область, Мытищинский район, г. Мытищи,
 Осташковское шоссе, д.1, РОССИЯ

BR Importado e distribuído por LEROY MERLIN
 CIA BRASILEIRA DE BRICOLAGEM
 Rua Domingas Galleteri Blotta, 315 - Interlagos - CEP
 04455-360 São Paulo - SP - Brazil CNPJ: 01.438.784/0001-05
 CALM (Central de Atendimento Leroy Merlin) -4020.5376 (capitais)
 e 0800.0205376 (demais regiões)

SA Imported by Adeo South Africa (PTY) LTD T/A Leroy
 Merlin - Leroy Merlin Greenstone Store - Corner
 Blackrock Street and Stoneridge Drive, Greenstone
 Park Ext 2, Edenvale, 1610 - Johannesburg,
 Gauteng, South Africa

KZ «Леруа Мерлен Қазақстан» ЖШС Қазақстан
 Республикасы, 050000, Алматы қ., Қонаев
 көшесі, 77, «ParkView» БО, БК., 07 оғ.

