

Product identification

Adeo Ref	844628		
Product EAN	3276000589839		
Supplier ref	58K629KFXCP65		

Template version history

Version	Status	Date Status	Comments
V.0	Under construction	20/08/2018	Template construction

Object

Technical data sheet of products

Technical data

Name product	KITCHEN FAUCET LILY ACS DELINIA CHR	Contain battery	
Power in Watt		Weight of the battery (gram)	
Nett Weight in gram (without batteries, without packaging)	1213 gram +/-5%	Type of battery (Li-ion / Alkalin, ...)	
Size of product: LxHx in centimetre	21.7x10.1x39.8		
Accessories included: detailed it	Base, anti-skidding o-ring, triangle plastic, triangle o-ring, plastic o-ring, threaded sleeve, tube cover, plastic screw, flexible hoses, shower hose, weight.		
Weight packaging	358 g		
Size packaging	53x23.5x6.5		

Remark: The main technical features could be adjusted by supplier based on different kinds of products.

Photo

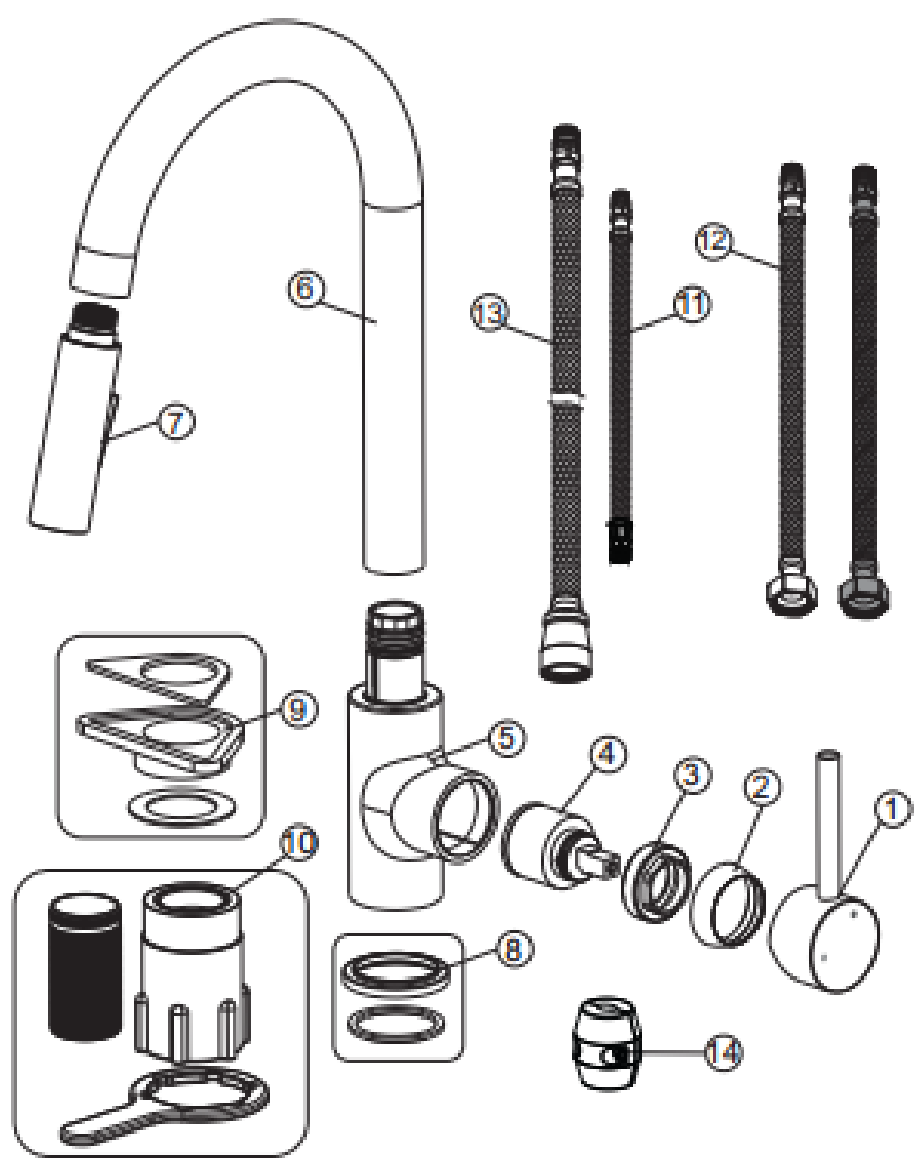
No	Description	Code No.	Q'Ty	Remark
1	Handle	5710Y027A00CP/BN	1	
2	Beautify Cover	5614B205A0ACP/BN	1	
3	Pressing Nut	5613B187A1ANT	1	
4	Cartridge	SN-35 COLD S/D MIRROR 08SN35S1501	1	
5	Body	5690Y629KAXCP/BN	1	
6	Spout	5628G209A0CP/BN	1	
7	Pull -out spout(aeartor)	5629Z441A0TCP/BN (44.2100.000)	1	
8	Base	5633Y172A0XCP/BN	1	
9	Triangle base	5635Q319A0PNT	1	
10	Fixing set	5626Q086A0TNT	1	
11	Spout supply hose	TAQ PEX DN6 ACB M8x1 L12 M11x1-300-QB	1	
12	Supply hose	TAQ-PEX-DN6-ACB H3/8-M8x1 L12-550	2	
13	Pull-out spout hose	TWIST-M11x1-H1/2con-1500	1	
14	Counter weight	5635Q328A1TNT	1	