

DN8

ITEM	QTY	CODE	COMPONENT DESCRIPTION	MATERIAL	TREATMENT
1	1	413488	TWIST-DN8-ACB	PERT-PET BRAIDING	-
	1		411621	Corrugated Tube	PERT
	1		111729	Braiding Wire	PET BRAIDING
2	2	413523	SLEEVE-DN8	AISI304	-
3	2	413139	Nipple DN8-1/2	Brass CW617N	-
4	2	412458.3	NUT-G12-H11.4	Brass Hpb58-3	Nickel-Plated
5	2	412730	WASHER G1/2	EPDM	-
6	1	23676	LABEL DN8	Polypropylene (PP)	-
7	1	Hanger	Hanger ADEO	Carton(PaperBoard)	-
8	1	22048	BRAID	Nylon-6/6	-

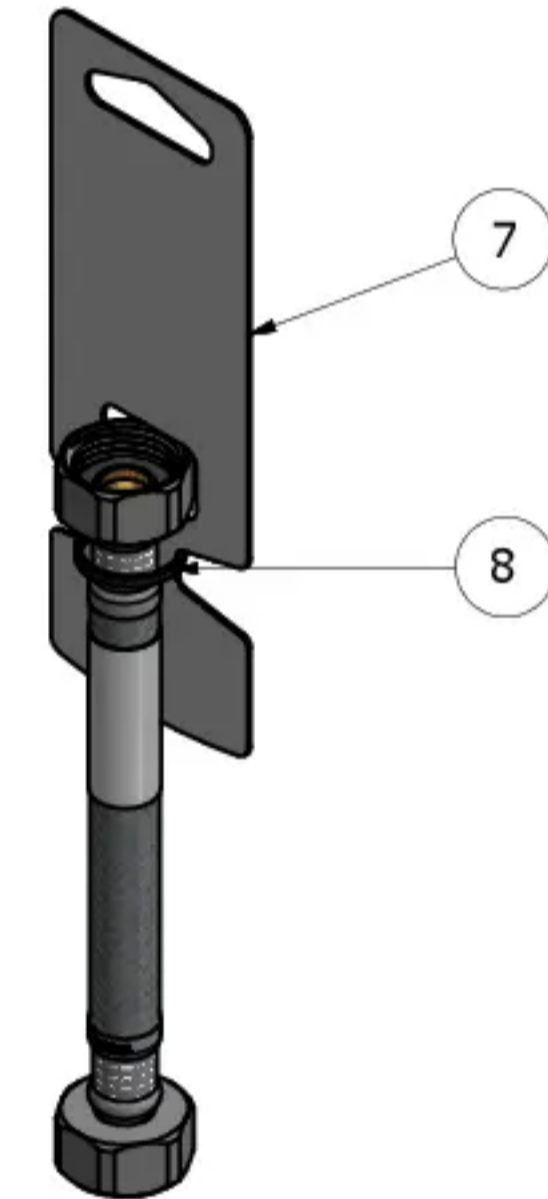
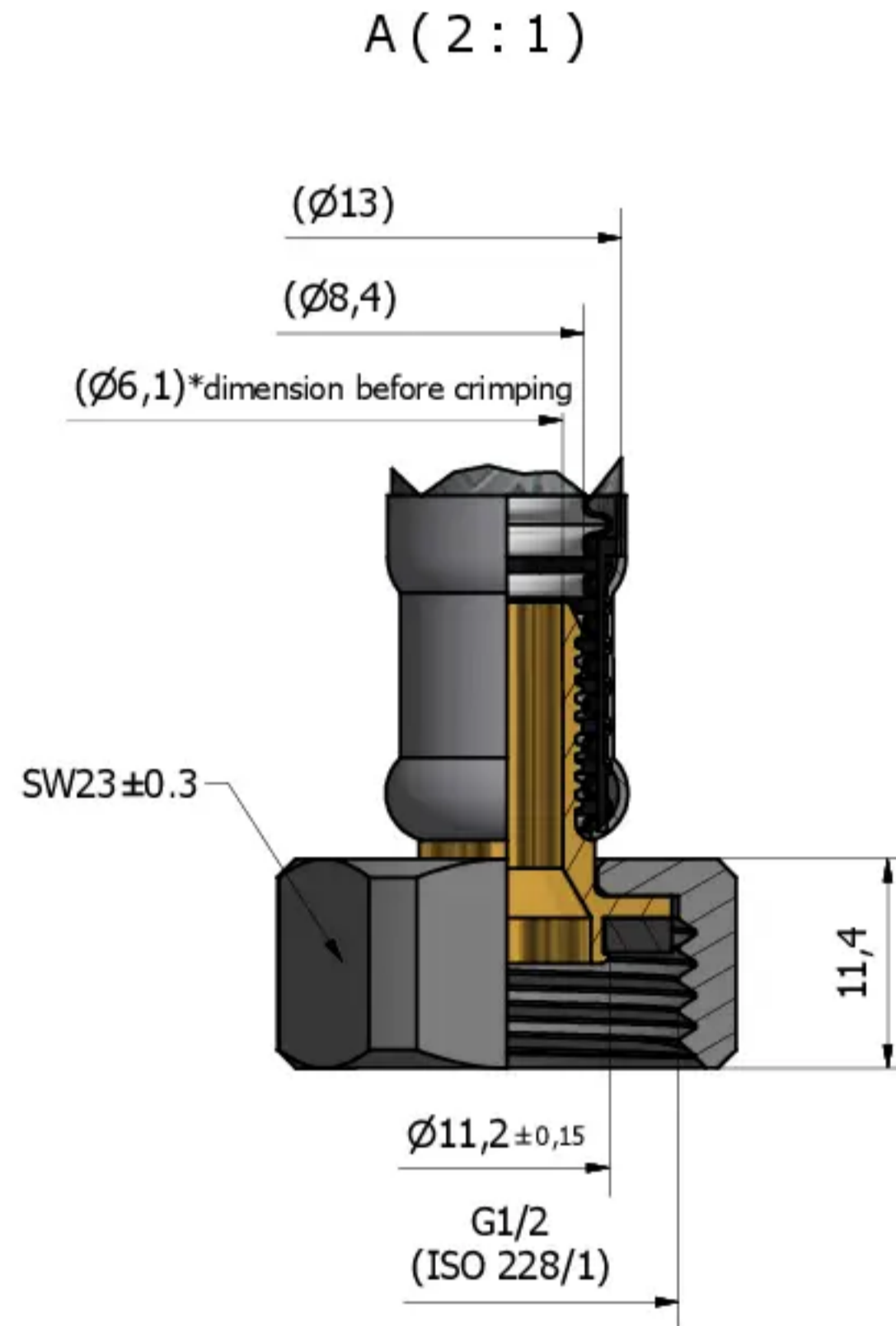
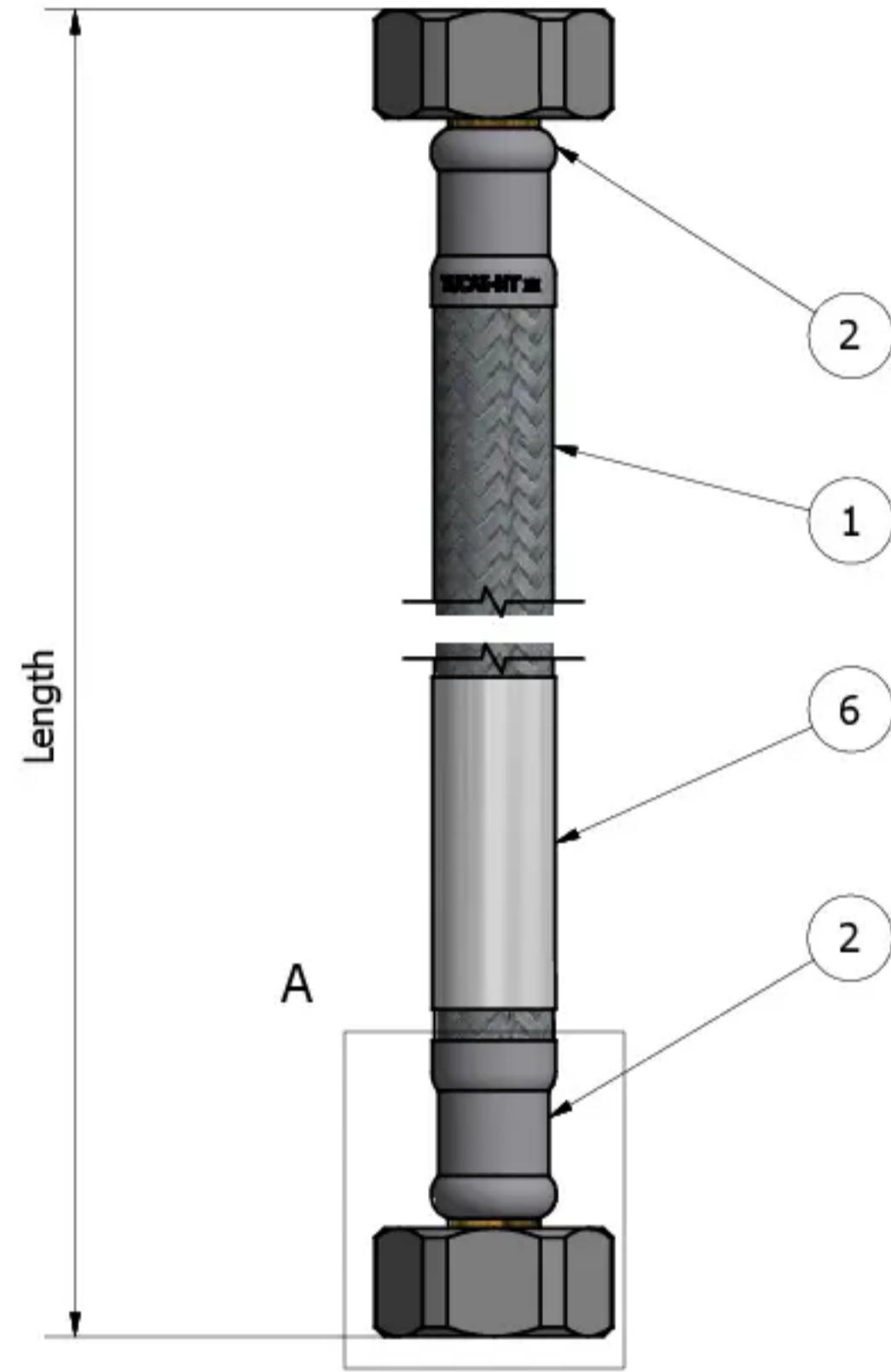

Code	Description	Length	Hanger	Customer Code	EAN client
208554	TWIST ACB-HG-1212-150	150+10/-0	23554	S202	3276007149074
208555	TWIST ACB-HG-1212-300	300+10/-0	23555	S206	3276007149159
208556	TWIST ACB-HG-1212-500	500+20/-0	23556	S210	3276007149241
208557	TWIST ACB-HG-1212-800	800+20/-0	23557	S214	3276007149319
208558	TWIST ACB-HG-1212-1000	1000+20/-0	23558	S218	3276007149395
208559	TWIST ACB-HG-1212-2000	2000+30/-0	23559	S222	3276007148879

NON TOLERANCED DIMENSIONS	NON TOLERANCED DIMENSIONS	NON TOLERANCED DIMENSIONS	NON TOLERANCED DIMENSIONS
from 0 to 6 mm. ±0.1	from 6 to 30 mm. ±0.2	from 30 to 120 mm. ±0.3	from 120 to 400 mm. ±0.5
BRASS MATERIAL SHALL BE STRESS RELIEVED			
NO SHARP EDGES PERMITTED			
MON. DIMENSIONED RADIUS 0.5 mm.			
NON TOLERANCED HEADS IN 3			
INSPECTION DIMENSION			
angle 30° ±1°	from 30° to 30° ±30°	from 30° to 120° ±20°	from 120° a 360° ±10°

DESIGNER	Vincent	2020/7/8
APPROVED BY	Fim	2020/7/8

HOSE ASSEMBLY



TWIST-ACB-HG-1212-ADEO

Code
208554-T
Code Prot.: