



Product Technical data sheet: Supplier Declaration

Product identification

Adeo Ref	830264		
Product EAN	3276007155228		
Supplier ref	ES19090		

Template version history

Version	Status	Date Status	Comments
V.0	Under construction	20/08/2018	Template construction
V.1	Validated construction	30/09/2019	Validated Template

Object

Technical data sheet of products

Technical data

Hangzhou Dunli Import and Export Co.,Ltd

No.1 Dunli Road, Renhe Street, Yuhang District, Hangzhou, China

Name product	CORNER METAL TWO BASKETS	Contain battery	NA
Power in Watt	NA	Weight of the battery (gram)	NA
Nett Weight in gram (without batteries, without packaging)	650±70g	Type of battery (Li-ion / Alkalin, ...)	NA
Size of product: LxHx in centimetre	217*217*385MM		
Accessories included: detailed it	As the follow picture		
Weight packaging	680±70g		
Size packaging	21.7*21.7*43.7cm		

Remark: The main technical features could be adjusted by supplier based on different kinds of products.

Photo

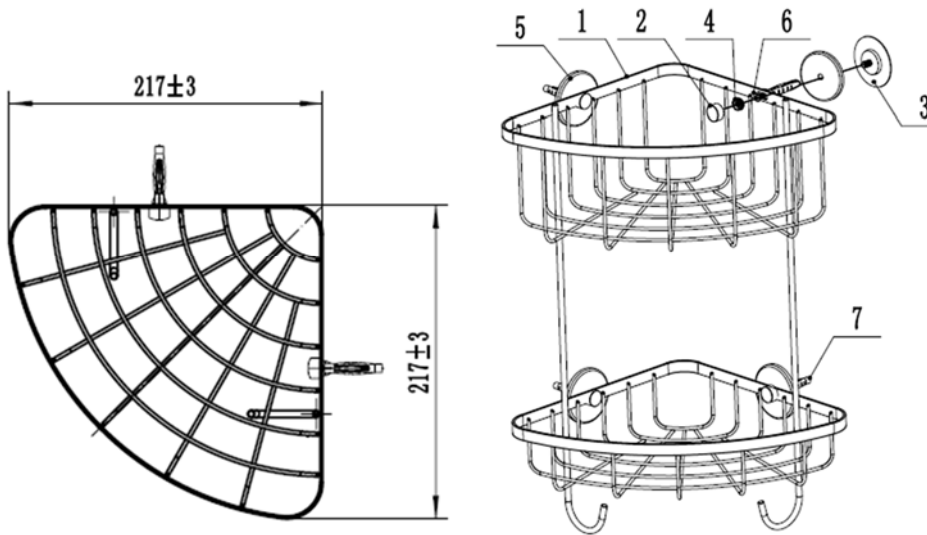
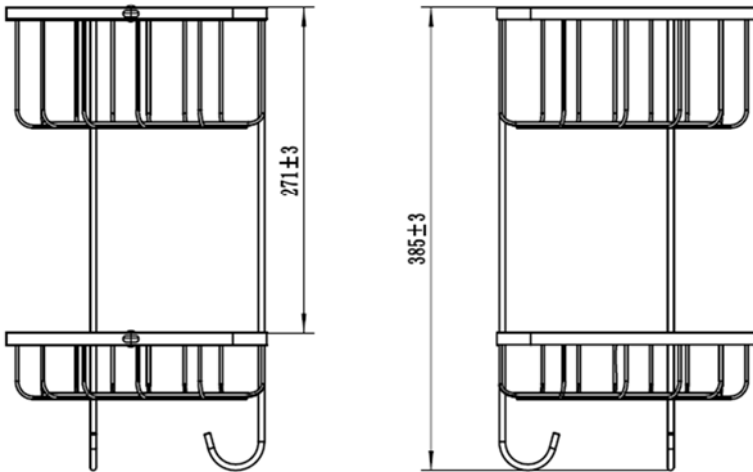

<p>installation I</p> <p>1. expending dowel 6*40 2. nut 3. screw 4. cap</p>	<p>installation II</p> <p>1. pad 2. cap 3. nut 4. cover</p>
---	---

7	ES19067.004	expending dowel 6*40	4	PP
6	ES19067.002	screw 4*50	4	stainless steel
5	HNLCP.T. ES19067.005	cover	4	ABS
4	HNLCP.T. ES19067.003	nut	4	zinc alloy
3	HNLCP.T. ES19067.006	pad	4	PVC
2	HNLCP.T. ES19067.001	cap	4	ABS
1	HNLCP ES19090.100	basket	1	metal powder coating
no.	code	name	Qty	material