



Product Technical data sheet: Supplier Declaration

Product identification

| | | | |
|--------------|---------------|--|--|
| Adeo Ref | 830270 | | |
| Product EAN | 3276007155402 | | |
| Supplier ref | NE19080 | | |
| | | | |

Template version history

| Version | Status | Date Status | Comments |
|---------|------------------------|-------------|-----------------------|
| V.0 | Under construction | 20/08/2018 | Template construction |
| V.1 | Validated construction | 30/09/2019 | Validated Template |
| | | | |
| | | | |

Object

Technical data sheet of products

Technical data

Hangzhou Dunli Import and Export Co.,Ltd

No.1 Dunli Road, Renhe Street, Yuhang District, Hangzhou, China



| | | | |
|--|------------------------|---|----|
| Name product | ANGLE BASKET NEO BLACK | Contain battery | NA |
| Power in Watt | NA | Weight of the battery (gram) | NA |
| Nett Weight in gram (without batteries, without packaging) | 480±50g | Type of battery (Li-ion / Alkalin, ...) | NA |
| Size of product: LxH in centimetre | 223*223*150MM | | |
| Accessories included: detailed it | As the follow picture | | |
| Weight packaging | 530g±55g | | |
| Size packaging | 27*20.9*13.7cm | | |
| | | | |
| | | | |

Remark: The main technical features could be adjusted by supplier based on different kinds of products.

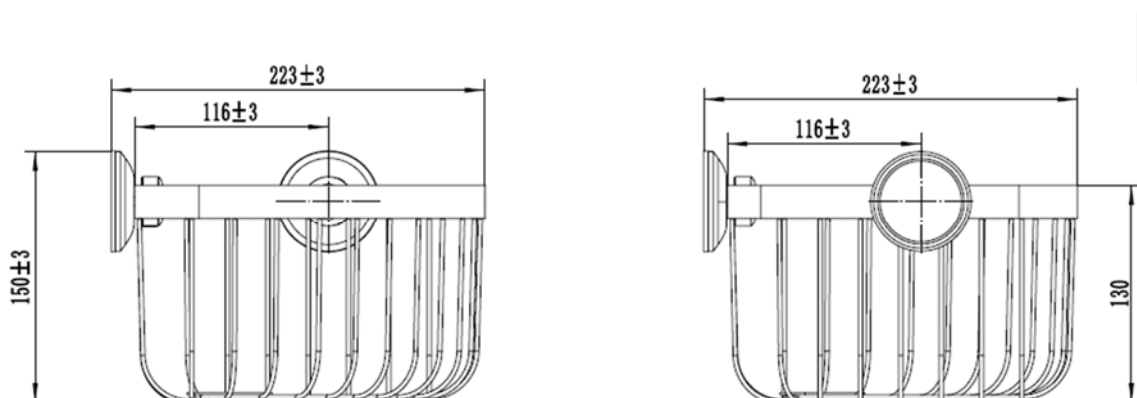
Photo

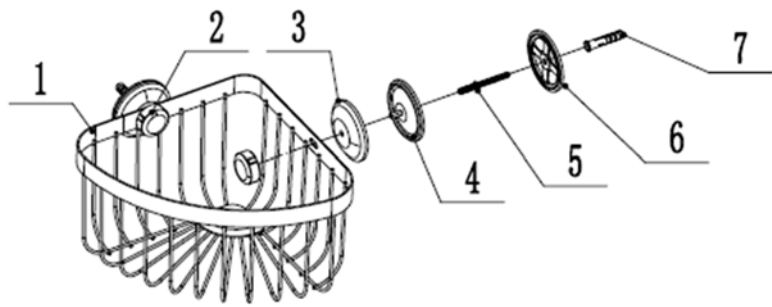
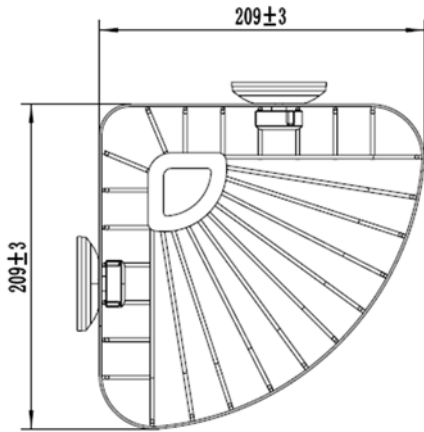



| | |
|---|--|
| <p>① installation</p> <p>1. expending dowel ϕ8*40</p> <p>2. plastic gasket</p> <p>3. screw</p> <p>4. cover</p> <p>5. cap</p>  | <p>② installation</p> <p>1. rubber base</p> <p>2. cover</p> <p>3. cap</p>  |
|---|--|

| | | | | |
|-----|----------------------|-----------------------|-----|----------------------------|
| 7 | HNLCPT. NE19074. 006 | expending dowel ϕ8×40 | 2 | PP |
| 6 | HNLCPT. NE19074. 005 | plastic gasket | 2 | ABS |
| 5 | HNLCPT. NE19074. 004 | screw | 2 | stainless steel |
| 4 | HNLCPT. NE19074. 003 | rubber base | 2 | rubber |
| 3 | HNLCPT. NE19074. 002 | cover | 2 | ABS |
| 2 | HNLCPT. NE19074. 001 | cap | 2 | ABS |
| 1 | HNLCPT. NE19080. 100 | basket | 1 | ss201 powder coating black |
| no. | code | name | Qty | material |