



Product Technical data sheet: Supplier Declaration

Product identification

Adeo Ref	830262		
Product EAN	3276007155365		
Supplier ref	NE19077		

Template version history

Version	Status	Date Status	Comments
V.0	Under construction	20/08/2018	Template construction
V.1	Validated construction	30/09/2019	Validated Template

Object

Technical data sheet of products

Technical data

Hangzhou Dunli Import and Export Co.,Ltd

No.1 Dunli Road, Renhe Street, Yuhang District, Hangzhou, China

Name product	BASKET WITH SOAP HOLDER NEO BLACK	Contain battery	NA
Power in Watt	NA	Weight of the battery (gram)	NA
Nett Weight in gram (without batteries, without packaging)	500g±50g	Type of battery (Li-ion / Alkalin, ...)	NA
Size of product: LxH in centimetre	310*136*150MM	material	STAINLESS STEEL
Accessories included: detailed it	As the follow picture		
Weight packaging	545±55g		
Size packaging	37*12.2*13.7cm		

Remark: The main technical features could be adjusted by supplier based on different kinds of products.

Photo

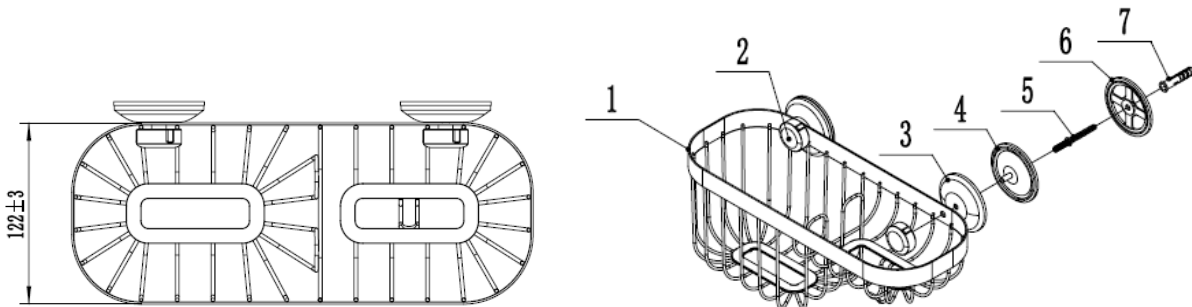
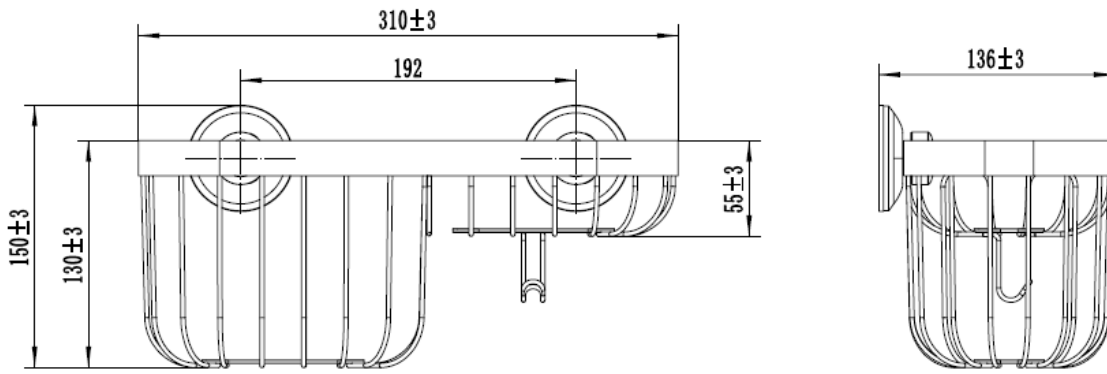

<p>①</p> <p>installation</p>	<p>1. expending dowel φ8*40</p> <p>2. plastic gasket</p> <p>3. screw</p> <p>4. cover</p> <p>5. cap</p>	<p>②</p> <p>installation</p>	<p>1. rubber base</p> <p>2. cover</p> <p>3. cap</p>
------------------------------	--	------------------------------	---

7	HNLCP.T. NE19074. 006	expending dowel φ8×40	2	PP
6	HNLCP.T. NE19074. 005	plastic gasket	2	ABS
5	HNLCP.T. NE19074. 004	screw	2	stainless steel
4	HNLCP.T. NE19074. 003	rubber base	2	rubber
3	HNLCP.T. NE19074. 002	cover	2	ABS
2	HNLCP.T. NE19074. 001	cap	2	ABS
1	HNLCP.T. NE19077. 100	basket	1	ss201 power coating black
no.	code	name	Qty	material