

幅面: A4
比例: 1:1

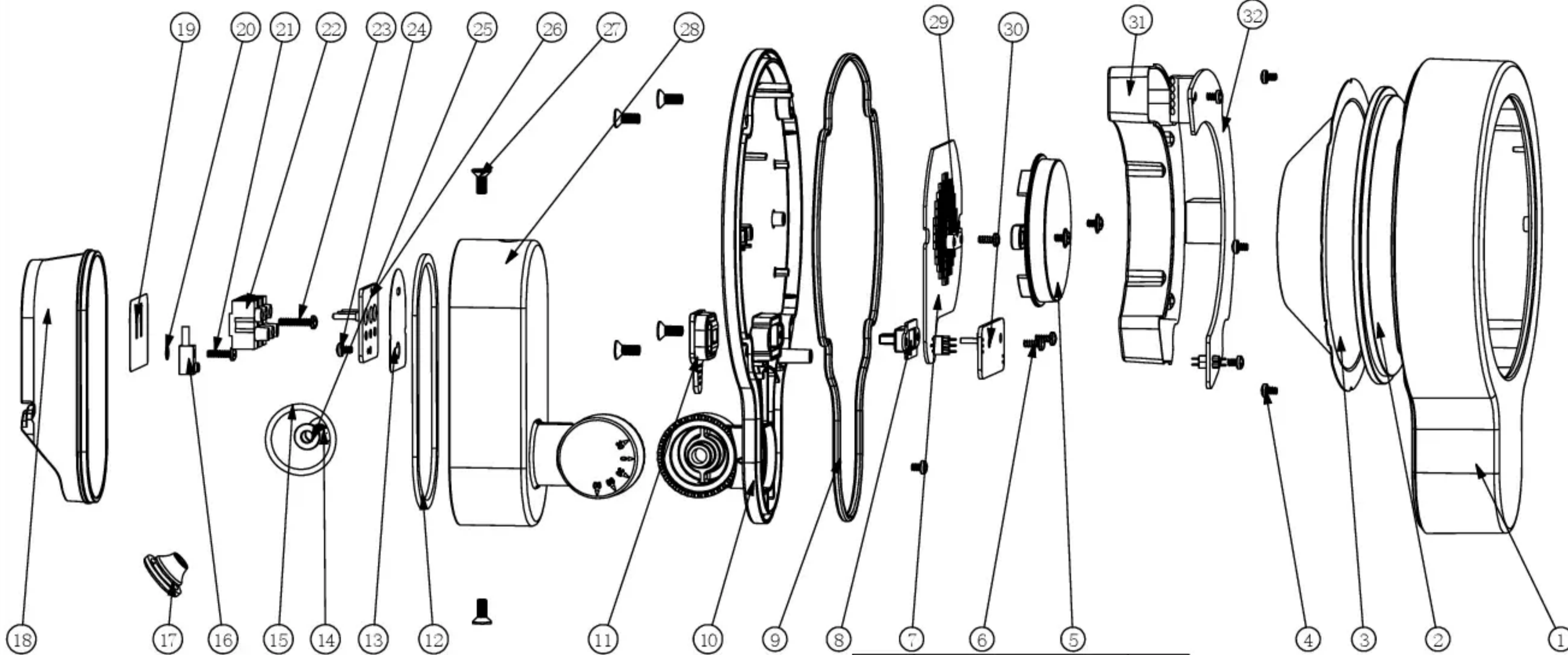

| NO. | Description | Quan. |
|-----|---------------------|-------|
| 1 | Cover | 1 |
| 2 | Glass | 1 |
| 3 | Reflector | 1 |
| 4 | Screw strip 2.9X4.0 | 6 |
| 5 | Hood | 1 |
| 6 | Screw ST2.9X6.5 | 6 |
| 7 | Aluminum plate | 1 |
| 8 | Silicone cover | 1 |
| 9 | Foamed silicone | 1 |
| 10 | Back cover | 1 |
| 11 | Sealing plug | 1 |
| 12 | Base seal | 1 |
| 13 | Base insulate sheet | 1 |
| 14 | Screw M6X20 | 1 |
| 15 | Shaft seal | 1 |
| 16 | Terminal | 1 |
| 17 | Guard coil | 1 |
| 18 | Bottom plate | 1 |

| NO. | Description | Quan. | NO. | Description | Quan. |
|-----|-----------------------|-------|-----|-------------------|-------|
| 19 | Bottom insulate sheet | 1 | 27 | Screw M4X10 | 6 |
| 20 | Washer Φ3 | 1 | 28 | Base | 1 |
| 21 | Screw ST2.9X10 | 1 | 29 | Crimping clip | 1 |
| 22 | Terminal | 1 | 30 | Palette | 1 |
| 23 | Screw ST2.9X14 | 1 | 31 | Drive blister box | 1 |
| 24 | Screw ST2.9X4.0 | 2 | 32 | Driver PCB | 1 |
| 25 | Shaft ring | 1 | | | |
| 26 | Adapter board | 1 | | | |

| 第一视角 | | |
|-----------|-------|------|
| | | |
| 尺寸(mm) | 公差 | 角度公差 |
| 0-(10) | ±0.10 | ±1° |
| 10-(50) | ±0.15 | |
| 50-(100) | ±0.20 | |
| 100-(160) | ±0.30 | |
| >160 | ±0.40 | |

| 版本 | DCN NO. | 修改描述 | 修订日期 |
|----|---------|------|------|
| | | | |

| | | |
|---------------------|----|--|
| 未做特殊说明 单位为毫米(mm) | 制图 | |
| | 设计 | |
| | 校对 | |
| | 核准 | |

TOSPO 得邦® 照明

| | | |
|-----------------------|---------------------|--------|
| 图纸名称: FOGGY-常规版爆炸图 | | |
| 图号: | 编制日期: 2022/03/05 | 第 01 页 |
| 版本号: V01 | | 共 01 页 |

未经公司允许, 该文档和数据不得全部或部分复制