



## Product Technical data sheet: Supplier Declaration

### Product identification

Adeo Ref	830255		
Product EAN	3276007155198		
Supplier ref	ES19066		

### Template version history

Version	Status	Date Status	Comments
V.0	Under construction	20/08/2018	Template construction
V.1	Validated construction	30/09/2019	Validated Template

### Object

Technical data sheet of products

### Technical data

Hangzhou Dunli Import and Export Co.,Ltd

No.1 Dunli Road, Renhe Street, Yuhang District, Hangzhou, China

Name product	ANGLE METAL BASKET	Contain battery	NA
Power in Watt	NA	Weight of the battery (gram)	NA
Nett Weight in gram (without batteries, without packaging)	215±22g	Type of battery (Li-ion / Alkaline, ...)	NA
Size of product: LxH in centimetre	182*182*72.5MM	Material	IRON
Accessories included: detailed it	As the follow picture		
Weight packaging	245±25g		
Size packaging	18.2*18.2*8cm		

Remark: The main technical features could be adjusted by supplier based on different kinds of products.

### Photo

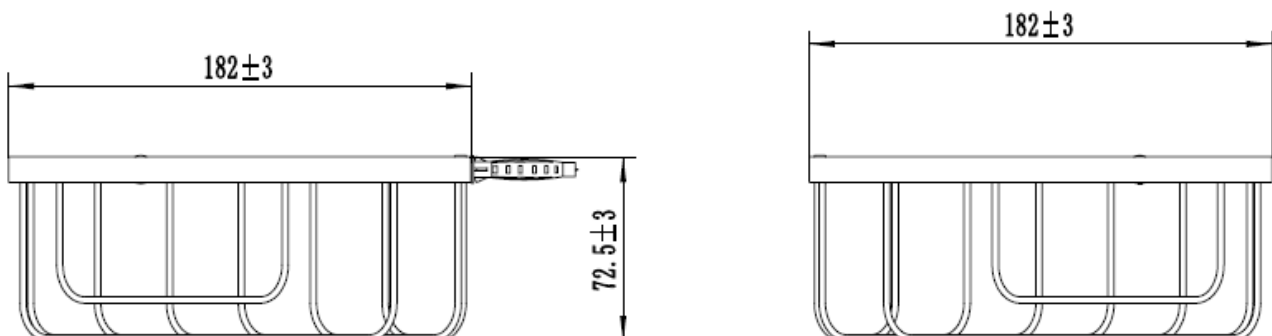

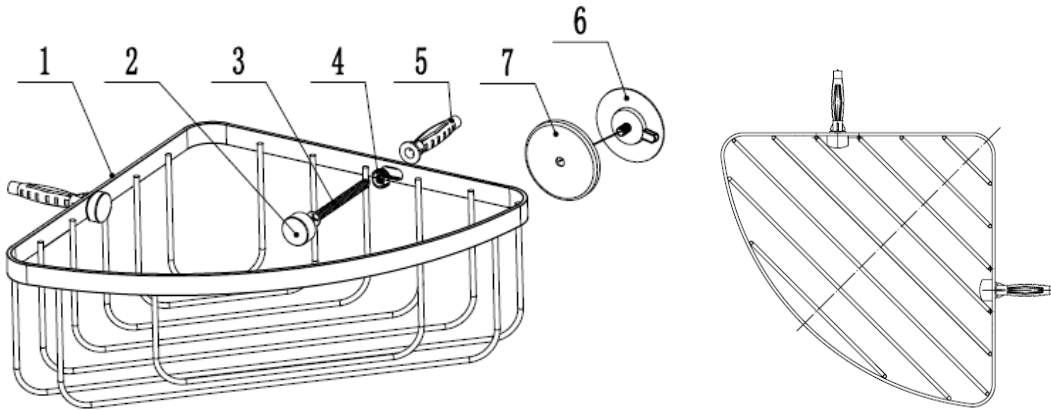

<p>installation I</p> <p>1. expending dowel 6*40</p> <p>2. nut</p> <p>3. screw</p> <p>4. cap</p>	<p>installation II</p> <p>1. pad</p> <p>2. cap</p> <p>3. nut</p> <p>4. cover</p>
--	--

7	HNLCPT. ES19067.005	cover	2	ABS
6	HNLCPT. ES19067.006	pad	2	PVC
5	ES19067.004	expending dowel 6*40	2	PP
4	HNLCPT. ES19067.003	nut	2	zinc alloy
3	ES19067.002	screw 4*50	2	stainless steel
2	HNLCPT. ES19067.001	cap	2	ABS
1	HNLCPT. ES19066.100	basket	1	metal powder coating
no.	code	name	Qty	material