



Product Technical data sheet: Supplier Declaration

Product identification

Adeo Ref	828403		
Product EAN	3276007187137		
Supplier ref	SR0019		

Template version history

Version	Status	Date Status	Comments
V.0	Under construction	20/08/2018	Template construction
V.1	Validated construction	30/09/2019	Validated Template

Object

Technical data sheet of products

Technical data

Hangzhou Dunli Import and Export Co.,Ltd

No.1 Dunli Road, Renhe Street, Yuhang District, Hangzhou, China

Name product	SHOE RACK	Contain battery	NA
Power in Watt	NA	Weight of the battery (gram)	NA
Nett Weight in gram (without batteries, without packaging)	1730g	Type of battery (Li-ion / Alkalin, ...)	NA
Size of product: LxH in centimetre	55-75*20.5*32CM	material	IRON,WOOD
Accessories included: detailed it	As the follow picture		
Weight packaging	1965g		
Size packaging	65*5*21.5cm		

Remark: The main technical features could be adjusted by supplier based on different kinds of products.

Photo

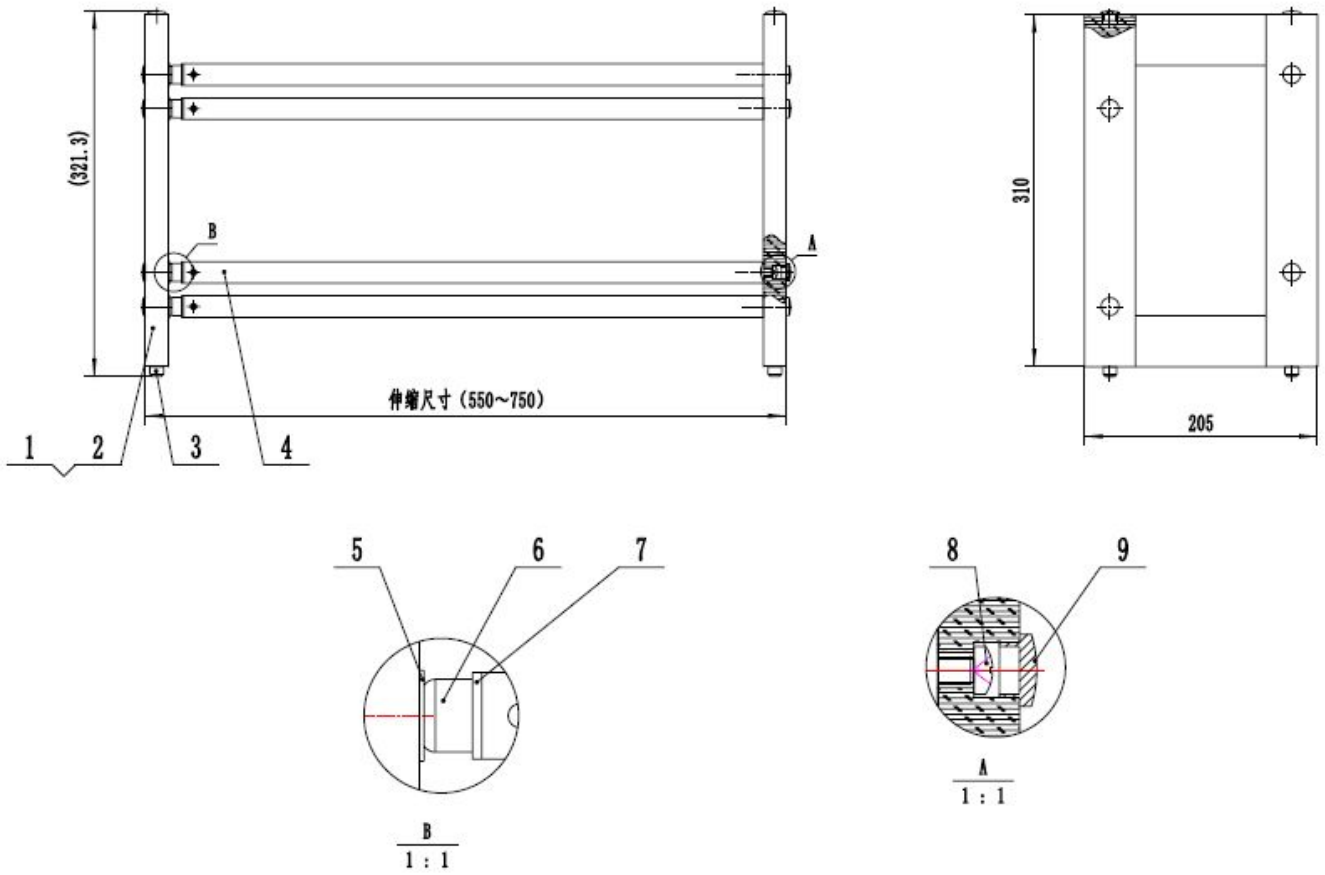

9	HNLCPT. 025677. 005	塑料塞	12	材质PE 颜色同客户确认样			外购
8	GB823	十字槽小盘头螺钉 M6X25	8				镀锌
7	HNLCPT. 025677. 004	管套	4	具体按实样			
6	HNLCPT. 025677. 200	连接管组件2	4				喷塑
5	GB/T 96. 2	大垫圈-C级 6	4				镀锌
4	HNLCPT. 025677. 100	连接管组件1	4				喷塑
3	HNLCPT. 025677. 003	底脚	4	Q235A			镀锌
2	HNLCPT. 025677. 002	右木框	1	松木			清漆
1	HNLCPT. 025677. 001	左木框	1	松木			清漆
序号	代号	名称	数量	材料	单件	总计	备注
					重量		